

300 – 480 MHz OOK Receiver with Decoder and 1 PWM Output

Features

- Embedded EEPROM
 - Very Easy Development with RFPDK
 - All Features Programmable
- Frequency Range: 300 to 480 MHz
- Symbol Rate: 0.1 to 40 ksps
- Sensitivity: -114 dBm at 1 ksps, 0.1% BER
- 3-wire SPI Interface for EEPROM Programming
- Stand-Alone, No External MCU Control Required
- Configurable Duty-Cycle Receive Mode
- 1 PWM Control Output
- Low Power Consumption: 3.8 mA
- Low Standby Current: 520 uA
- Support 1920 and 1527 Decoding Formats
- ID Study, Factory Code Supported
- RoHS Compliant
- 16-pin QFN 3x3 Package

Descriptions

The CMT2251A is a true single-chip, ultra low power and high performance device that consists of an OOK RF receiver, a data decoder and 1 PWM output pin for various 300 to 480 MHz wireless applications. The device integrates a data decoder that is not only compatible with the most common used packet format of 1527, but also a more efficient, flexible and powerful format of 1920 designed by CMOSTEK. The device delivers sensitivity up to -114 dBm while consuming only 3.8 mA current when it is always on. An embedded EEPROM allows the frequency, symbol rate and other features to be programmed into the device using the CMOSTEK USB Programmer and the RFPDK. Alternatively, in stock products of 433.92 MHz are available for immediate demands with no need of EEPROM programming. When pairing the device to CMOSTEK transmitter, the synchronization ID can be programmed into both of the transmitter and receiver during the manufacturing phase, or studied by the receiver from the transmitter remotely by end customers. The CMT2251A is part of the CMOSTEK NextGenRF™ family, together with CMT215x transmitters, they enable ultra low cost, low power consumption RF links.

Applications

- Smart LED Control (PWM)
- Low-Cost Consumer Electronics Applications
- Remote Control
- Fan Controller
- Wireless Controller with PWM Interface
- Home Security and Alarm
- Garage and Gate Openers
- Home and Building Automation
- Industrial Monitoring and Controls
- Sensor Networks

Ordering Information

Part Number	Frequency	Package	MOQ
CMT2251A-EQR	433.92 MHz	QFN16	5,000 pcs

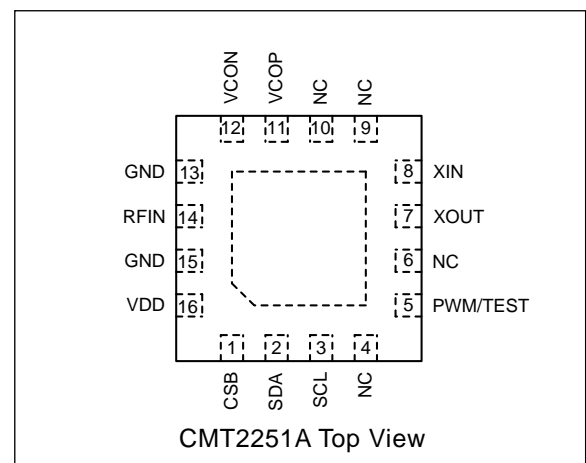

Typical Application

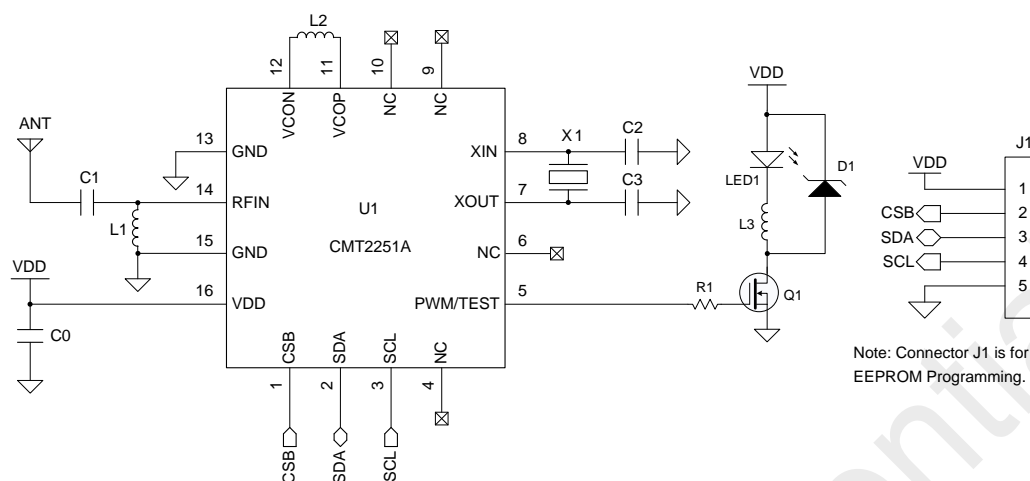

Figure 1. CMT2251A Typical Application Schematic

Table 1. BOM of Typical Application

Designator	Descriptions	Value(Match to 50Ω ANT)		Value(Common Used ANT)		Unit	Manufacturer
		315 MHz	433.92 MHz	315 MHz	433.92 MHz		
U1	CMT2251A, 300 – 480 MHz OOK receiver with decoder and 1 PWM output	-		-		-	CMOSTEK
X1	±20 ppm, SMD32*25 mm, crystal	26		26		MHz	EPSON
L1	±5%, 0603 multi-layer chip inductor	33	27	68	33	nH	Murata LQG18
L2	±5%, 0603 multi-layer chip inductor	33	22	33	22	nH	Murata LQG18
C1	±0.25 pF, 0402 NP0, 50 V	5.6	3.3	4.3	2.7	pF	Murata GRM15
C0	±20%, 0402 X7R, 25 V	0.1		0.1		uF	Murata GRM15
C2, C3	±5%, 0402 NP0, 50 V	27		27		pF	Murata GRM15
LED1	SMD 5050, orange LED	0.25		0.25		W	
R1	±5%, 0402 chip resistor	1.0		1.0		kΩ	
D1	MBR0520, SOD123 Schottky diode	0.5		0.5		A	
L3	SMD Φ=6mm, power inductor	68		68		uH	
Q1	SOT23, SI2312 20-V N-channel MOSFET	-		-			Vishay

Table 2. CMT2251A Pin Descriptions

Pin Number	Name	I/O	Descriptions
1	CSB	I	3-wire SPI chip select input for EEPROM programming
2	SDA	IO	3-wire SPI data input and output for EEPROM programming
3	SCL	I	3-wire SPI clock input for EEPROM programming
4, 6, 9, 10	NC	-	Not connected, leave floating
5	PWM/TEST	O	PWM control output Receiving data output for production test purpose
7	XOUT	O	Crystal oscillator output
8	XIN	I	Crystal oscillator input or external reference clock input

Pin Number	Name	I/O	Descriptions
11	VCOP	IO	VCO tank, connected to an external inductor
12	VCON		
13, 15	GND	I	Ground
14	RFIN	I	RF signal input to the LNA
16	VDD	I	Power supply input

Package Outline

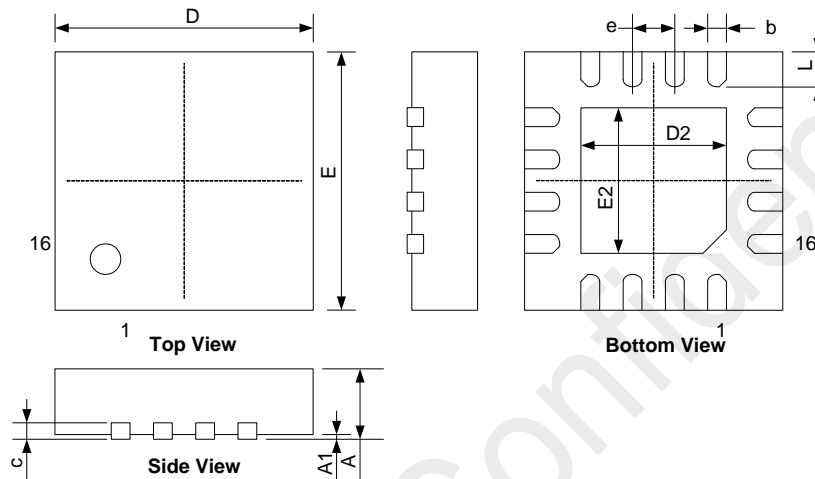

Figure 3. 16-Pin QFN 3x3 Package

Table 3. 16-Pin QFN 3x3 Package Dimensions

Symbol	Size (millimeters)	
	Min	Max
A	0.7	0.8
A1	-	0.05
b	0.18	0.30
c	0.18	0.25
D	2.90	3.10
D2	1.55	1.75
e	0.50 BSC	
E	2.90	3.10
E2	1.55	1.75
L	0.35	0.45

Copyright. CMOSTEK Microelectronics Co., Ltd. All rights are reserved.

The information furnished by CMOSTEK is believed to be accurate and reliable. However, no responsibility is assumed for inaccuracies and specifications within this document are subject to change without notice. The material contained herein is the exclusive property of CMOSTEK and shall not be distributed, reproduced, or disclosed in whole or in part without prior written permission of CMOSTEK. CMOSTEK products are not authorized for use as critical components in life support devices or systems without express written approval of CMOSTEK. The CMOSTEK logo is a registered trademark of CMOSTEK Microelectronics Co., Ltd. All other names are the property of their respective owners.