

CMT2210A Schematic and PCB Layout Design Guideline

1. Introduction

The purpose of this document is to provide the guidelines to design a low power consumption, low BOM and high sensitivity CMT2210A Receiver.

2. CMT2210A Schematics Guidelines

The CMT2210A is an ultra low power, high performance, low-cost OOK stand-alone RF receiver for various 300 to 480 MHz wireless applications. The chip is part of the CMOSTEK NextGenRF™ family, which includes a complete line of transmitters, receivers and transceivers. To give the CMT2210A schematic design guidelines, an example of 315/433.92 MHz application is given below.

2.1 CMT2210A Evaluation Module Schematic

Only a few external components are required for the CMT2210A. Further optimizations can be done by removing the connections of the optional pins.

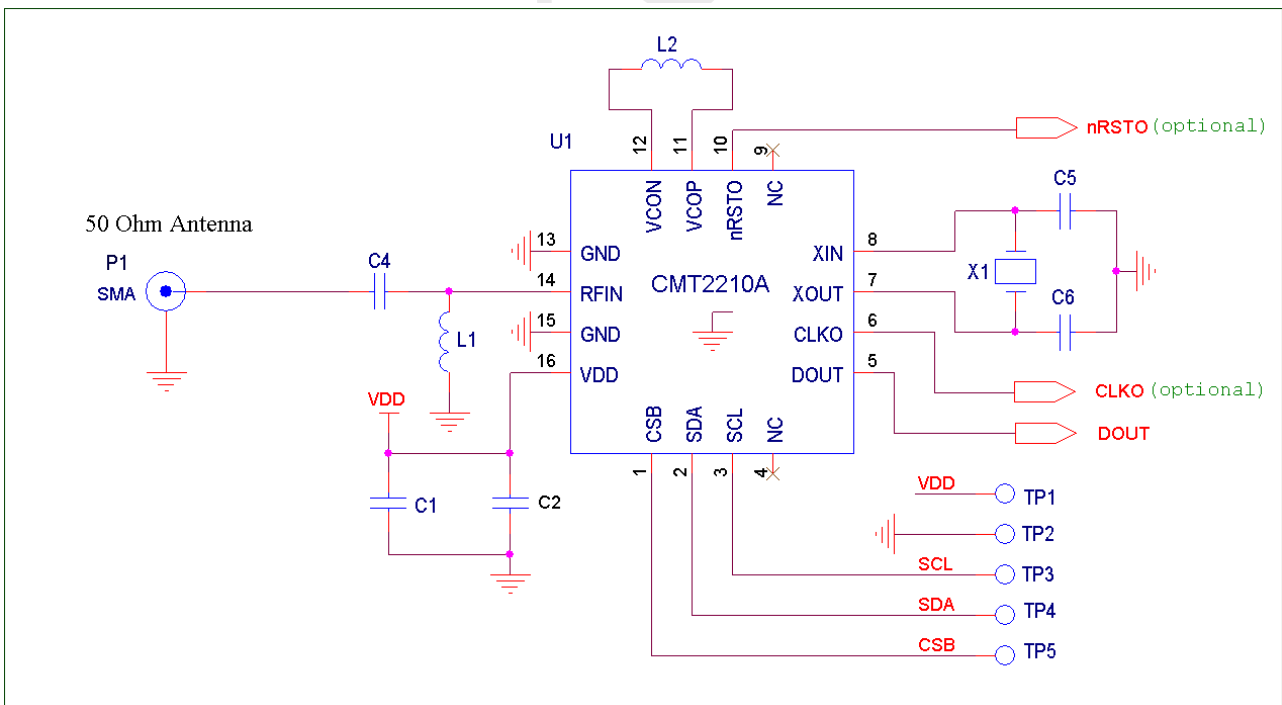

Figure 1. CMT2210A-EM Schematic

Notes:

1. L2 is the VCO tank inductor. The VCO oscillates at the frequency which is 2x of the RF frequency. In order to suppress the spurious emission and minimize phase noise, a high-Q inductor is used. For a 433.92 MHz design it is suggested to use a 22 nH inductor with $Q > 25$ at 800 MHz. For a 315 MHz design it is suggested to use a 33 nH inductor with $Q > 25$ at 600 MHz.
2. L1 and C4 transform the impedance seen at the RFIN pin to the antenna impedance.
3. C1 and C2 are the power supply decoupling capacitors. C1 is an optional decoupling capacitor depending on the power supply purity level.
4. The crystal oscillator consists of an extent crystal X1 and two loading capacitors (C5 and C6). The Total load capacitance seen between the crystal terminals should equal C_L for the crystal to oscillate at the specified frequency.

$$C_L = \frac{C5 * C6}{C5 + C6} + \frac{\Delta C}{2}$$

The parasitic capacitance ΔC is constituted by pin input capacitance and PCB stray capacitance. The ESR of the crystal should be within 60 Ω in order to ensure a reliable start-up. The total tolerance is ± 20 ppm typically, which include initial tolerance, crystal loading, aging, and temperature dependence. The acceptable tolerance depends on RF frequency and channel spacing/bandwidth.

5. An external clock source can easily be used in place of a crystal oscillator. The incoming clock signal is recommended to have a peak-to-peak swing in the range of 300 mV to 700 mV and AC-coupled to the XTAL pin.
6. P1 is a SMA connector for a 50 Ω antenna.
7. The DOUT pin outputs the demodulated data.
8. The test points (TP1/2/3/4/5 connected to VDD, GND, SCL, SDA, and CSB respectively) must be reserved if EEPROM programming is required. The CSB, SDA and SCL should be left un-connected if they are not used.
9. By default, an active low reset signal is generated by the internal POR and output via the nRSTO pin. It can be used to reset the external MCU if it is required. The CMT2210A can provide a configurable system clock output from the CLKO pin to drive the external device. The nRSTO and CLKO should be left un-connected if they are not used.
10. Pin descriptions of the CMT2210A, and the BOM for CMT2210A application are shown in Table 1 and Table 2.

Table 1. CMT2210A Pin Descriptions

Pin Number	Name	I/O	Descriptions
1	CSB	I	3-wire SPI chip select input for EEPROM programming
2	SDA	IO	3-wire SPI data input and output for EEPROM programming
3	SCL	I	3-wire SPI clock input for EEPROM programming
4,9	NC	-	Not connected, leave floating
5	DOUT	O	Received data output
6	CLKO	O	Programmable clock output to drive an external MCU
7	XOUT	O	Crystal oscillator output
8	XIN	I	Crystal oscillator input or external reference clock input
10	nRSTO	O	Active-low power-on-reset output to reset an external MCU
11	VCOP	IO	VCO tank, connected to an external inductor
12	VCON		
13, 15	GND	I	Ground
14	RFIN	I	RF input
16	VDD	I	Power supply input

Table 2. BOM of CMT2210A-EM Application

Designator	Descriptions	Value		Unit	Manufacturer
		315 MHz	433.92 MHz		
U1	CMT2210A 300-480MHz OOK receiver	-		-	CMOSTEK
L1	±5%,0603 multi-layer chip inductor	39	27	nH	Murata LQG18
L2	±5%,0603 multi-layer chip inductor	33	22	nH	Murata LQG18
C4	±0.25 pF, 0402 NP0, 50 V	4.3	3.3	pF	Murata GRM15
C1	±5%, 0402 NP0, 50 V, optional	470		pF	Murata GRM15
C2	±20%, 0402 X7R, 25 V	0.1		uF	Murata GRM15
C5, C6	±5%, 0402 NP0, 50 V	15		pF	Murata GRM15
X1	±20 ppm, SMD32*25 mm crystal	26		MHz	EPSON

3. CMT2210A PCB Layout Recommendations

The following PCB layout design guidelines take the CMT2210A-EM as an example.

CMT2210A-EM is a 2-layer PCB using FR4 PCB material. The thickness of the PCB is 0.8 mm; the thickness for the copper is 1 ounce (0.0356mm); the separation between ground pour copper and traces/pads is 0.3 mm; the dielectric constant (ϵ_r) for the FR4 material is 4.4. In general, the impedance of the coplanar transmission line is in proportion to the thickness of the PCB and the distance between the routing and grounding around it. It is in inverse proportion to the width/thickness of the routing and the dielectric constant (ϵ_r). Using a conventional transmission line calculator (such as Txline), a 1-mm width of the 50 Ω coplanar transmission line can be obtained.

3.1 CMT2210A-EM PCB Layout

The PCB layout as shown in Figure 2 has six sections. They are RF Input, Power Supply Decoupling, XTAL Circuit, VCO Tank Circuit, Digital Signals Routing, and Grounding.

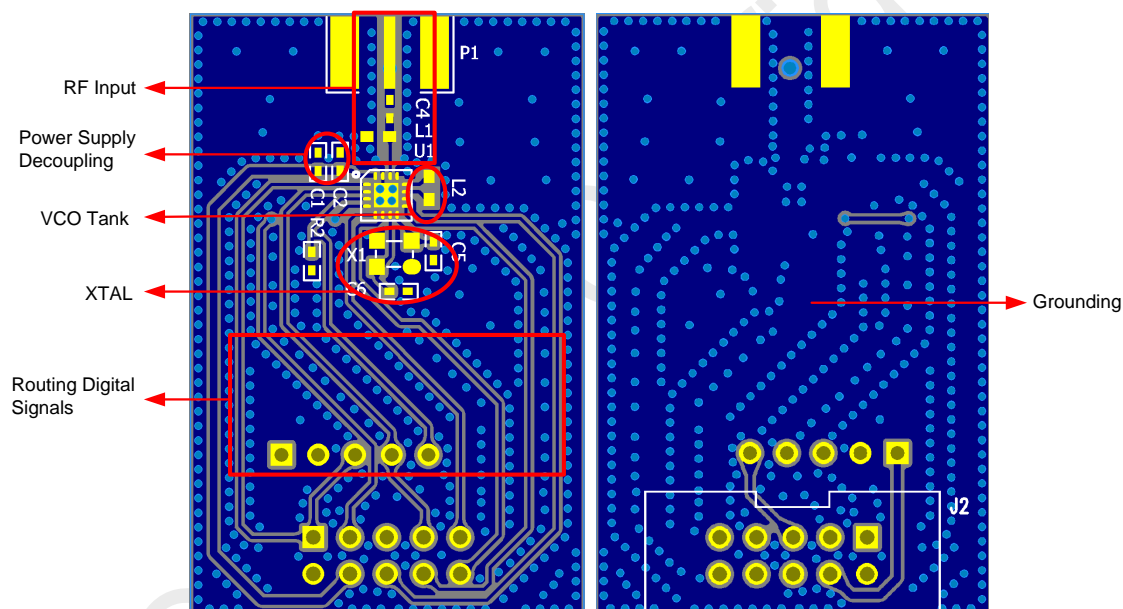

Figure 2. CMT2210A-EM PCB Layout

3.1.1 RF Input

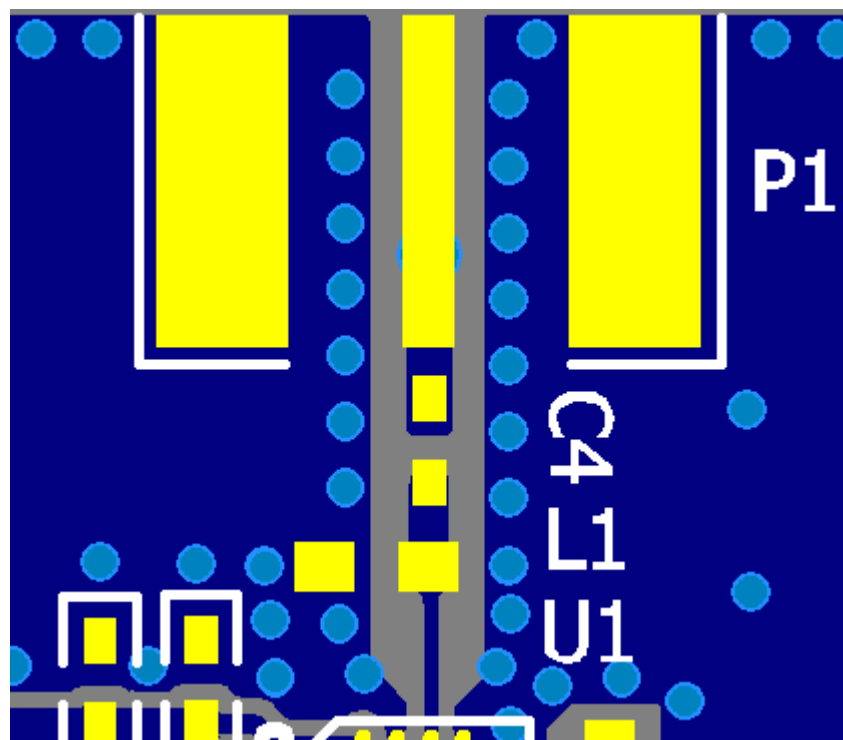

Figure 3. RF Input

The RF input section is shown in Figure 3.

1. Keep the RF signal routing as straight as possible to minimize the loss of the RF signal power.
2. Place the L1 and C4 as close to each other as possible, and also keep this matching network section as close to CMT2210A as possible.
3. The input of the LNA can be modeled as a shunt resistor R_{LNA} (340 Ω) in parallel with a shunt capacitor C_{LNA} (2.8 pF). A 0.2-mm width transmission line between the L1 and the CMT2210A is used. The width of the transmission line is 1 mm between L1 and the SMA connector which is of 50 Ω impedance.
4. It is suggested not to place any silk print on any RF component, as the silk print might impact the dielectric constant (E_r) of the PCB.
5. The ground pour flooding and the RF signal routing should be smooth to avoid the impedance variation on the transmission lines, which will result in RF signal reflection and performance inconsistency in mass production. Wherever possible the bottom (copper) side of the board should allow for a solid ground plane under the RF.
6. P1 is a SMA connector for the antenna. The monopole antenna is a very popular antenna which most commonly refers to a quarter-wavelength ($\lambda/4$). One antenna element is one $\lambda/4$ wavelength and the GND plane acts as the other $\lambda/4$ wavelength which produces an effective $\lambda/2$ antenna. Therefore, for monopole antenna designs the performance of the antenna depends on the ground size. Considering cost, performance and time-to-market, the user can choose different types of monopole antenna, including PCB antenna, chip antenna, whip antenna or wire antenna. CMT2210A-EM uses a whip antenna for optimal RF performance.

3.1.2 Power Supply Decoupling

1. Place C1 and C2 as close to the power supply of CMT2110A as possible, as shown in the figure below.

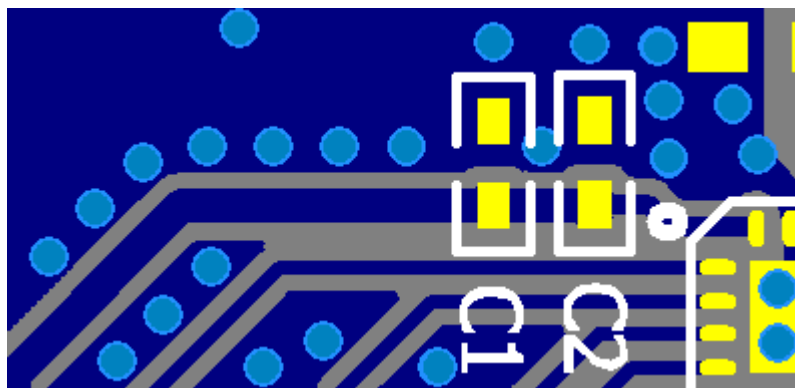

Figure 4. Power Supply Decoupling Layout

3.1.3 XTAL

Place the crystal as close as possible to the XTAL pin and keep the routing as short as possible in order to reduce any frequency offsets that may occur. Avoid routing digital signals with sharp edges close to XIN PCB track or underneath the crystal X1 pad, as this may shift the crystal DC operating point and result in duty-cycle variation. The XTAL circuit is shown in the figure below.

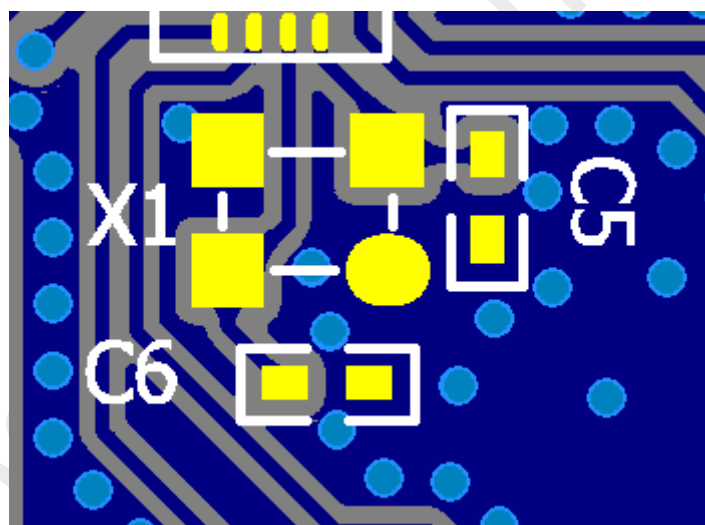

Figure 5. XTAL Circuit Layout

3.1.4 Digital Signals Routing

The digital signals must be routed away from the RF, the XTAL and the VCO circuit to avoid high frequency harmonics coupling to those sensitive signals. The solid ground should be placed among the SDA, CSB and SCL signal routings to avoid cross-coupling if possible. R2 is a resistor for internal use only. The user does not need to include it in the design.

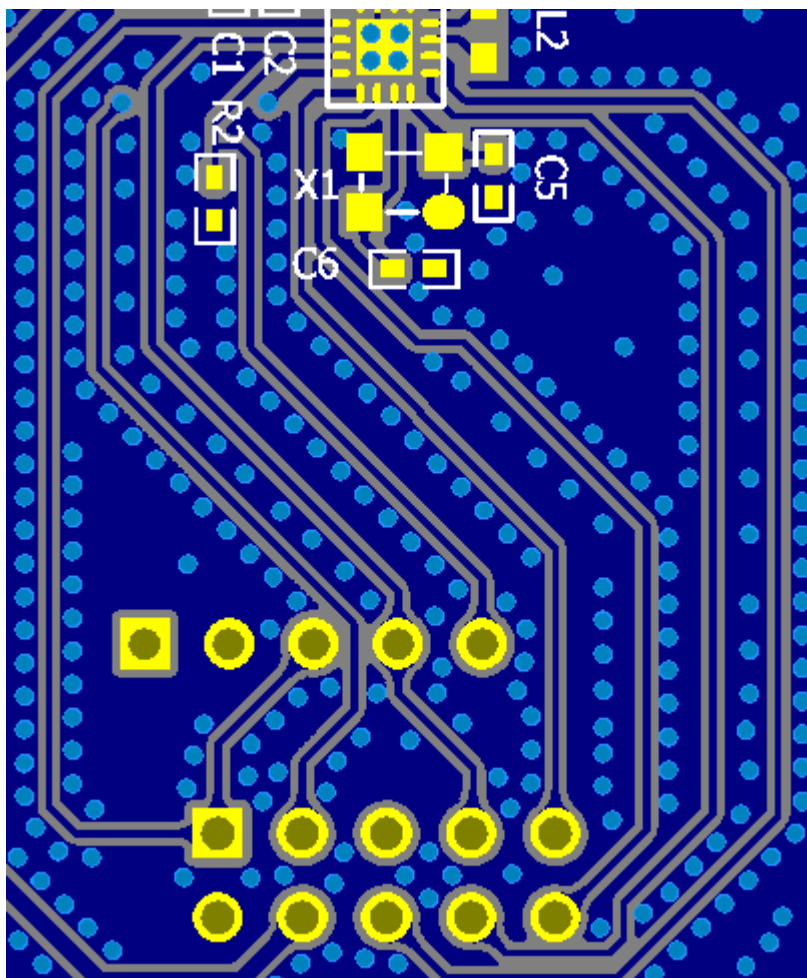

Figure 6. Digital Signals Routing

3.1.5 VCO Tank

As the VCO tank inductor L2 is connected to a differential input, the PCB layout should endeavor to respect the symmetry of this port. To minimize the radiation from the VCO circuit and maintain the high Q factor of the VCO tank, L2 should be placed as close as possible to the CMT2210A. The VCO tank is surrounded by a solid ground plane. This ground trace along with the ground vias minimizes the radiation from the VCO, and suppresses the noise injected into the VCO tank. See figure below for the VCO tank layout.

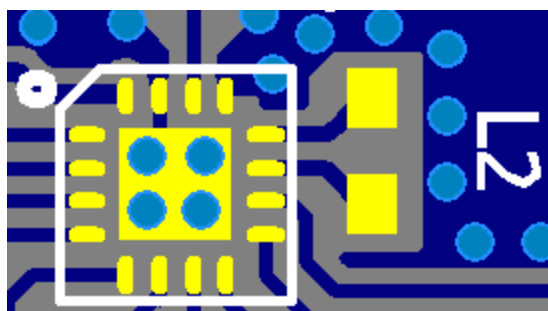

Figure 7. VCO Tank Layout

3.1.6 Grounding

1. Use as much continuous ground plane metallization as possible.
2. Place a series of ground vias along the PCB edges if possible. The maximum distance between the vias should be less than $\lambda/10$. This is required to reduce the PCB radiation at higher harmonics caused by the fringing field of routing edges.

CMOSTEK Confidential

4. Document Change List

Table 3. Document Change List

Rev. No	Chapter	Description of Changes	Date
0.9		Initial released version	2014-06-14
1.0	-	-	2014-06-30

CMOSTEK Confidential

5. Contact Information

CMOSTEK Microelectronics Co., Ltd.

Room 202, Honghai Building, Qianhai Road. Nanshan District

Shenzhen, Guangdong, China PRC

Zip Code: 518000

Tel: 0755 - 83235017

Fax: 0755 - 82761326

Sales: sales@cmostek.com

Technical support: support@cmostek.com

www.cmostek.com

Copyright. CMOSTEK Microelectronics Co., Ltd. All rights are reserved.

The information furnished by CMOSTEK is believed to be accurate and reliable. However, no responsibility is assumed for inaccuracies and specifications within this document are subject to change without notice. The material contained herein is the exclusive property of CMOSTEK and shall not be distributed, reproduced, or disclosed in whole or in part without prior written permission of CMOSTEK. CMOSTEK products are not authorized for use as critical components in life support devices or systems without express written approval of CMOSTEK. The CMOSTEK logo is a registered trademark of CMOSTEK Microelectronics Co., Ltd. All other names are the property of their respective owners.